



**SOLID**  
TO SUCCEED

ARTICULATED BOOM LIFT

# XGA18E



The print does not belong to the contract, nor a part of the vehicle purchase contract. We reserve the right to revise the product model, parameters, configuration based on the continuous improvement requirements of the product, without prior notice. Pictures are for reference only, and the specific product shall depend on the real product.

# XGA18E

## Articulated boom lift

### FEATURES

#### MEASUREMENTS

18.01m working height  
Up to 256/350kg lift capacity

#### PRODUCTIVITY

1.83m × 0.76m steel platform  
4 driving wheels  
2 steering wheels  
45% theoretical gradeability  
Axle balance system  
Solid rubber tires  
Platform automatic leveling system  
160° platform rotation  
Fully proportional multi-function controls  
Hydraulic oil cooler  
Enable switch  
Hourmeter record  
Tilt alarm  
Lift and lower alarm  
Drive alarm  
360° continuous turntable rotation  
Lockable canopy  
High/Slow speed mode  
Turntable control box  
Engine status displayer  
Flashing beacon

#### POWER

Engine protection devices  
Kubota Euro stage V emission  
12V DC emergency power

### OPTIONS

Tool tray  
Platform working light  
AC power to the platform  
Platform anti-collision device  
Foam-filled rough terrain tires

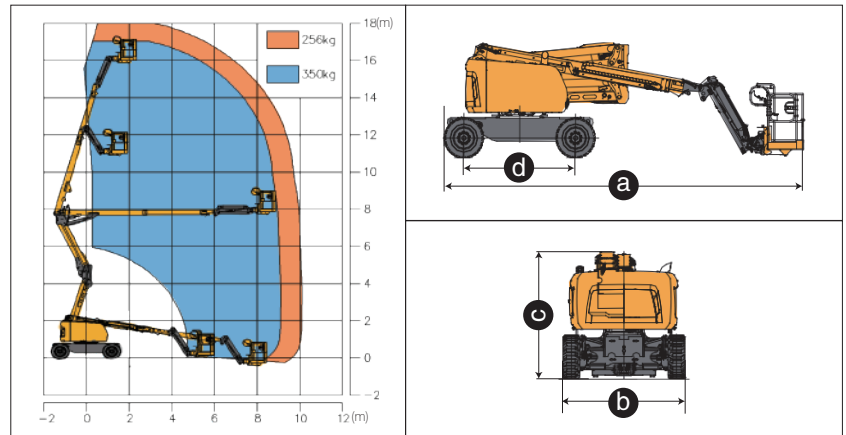

Item	Unit	XGA18E
Working height	m	18.01
Platform height	m	16.01
Working radius	m	10.26
Lift capacity	kg	256/350
Occupant capacity	-	2
1st Boom luffing range	°	0~65
2nd Boom luffing range	°	-11~+75
Fly jib luffing range	°	-65~+70
Turntable rotation	°	360
Platform rotation	°	160
Drive speed (retracted/extended)	km/h	5.5/0.6
Turning radius (inside/outside)	m	1.9/4.7
Tailswing	mm	0
Ground clearance	mm	300
Gradeability	%	45
Tires	-	33×12
Power source	-	Kubota V2403
Rated power	kW/(r/min)	36.8/(2700)
Fuel tank	L	65
Hydraulic tank	L	85
Weight	kg	8700
Platform size	mm	1830×760
a Length (transportation)	mm	7640/5700
b Width	mm	2320
c Height	mm	2380
d Wheelbase	mm	2360