

T41-140SLP 100 V R-Series Telescopic Handler

Telescopic Specifications

Performance

Rated capacity	4100 kg
Capacity (at max. height on tyres)	2500 kg
Capacity at max. height on stabilizers	3500 kg
Capacity at max. reach on stabilizers	1000 kg
Lifting height	13300.0 mm
Lifting height on stabilizers	13656.0 mm
Tilt Breakout force	12300 daN
Drawbar pull (24" tyres)	4900 daN
Max. gradeability (24" tyres)	29.0°
Max. reach	9449.0 mm
Lifting height on stabilizers (24" tyres)	13656.0 mm
Max. reach on stabilizers (24" tyres)	9720.0 mm

Cycle times

Boom raising	14.0 s
Boom lowering	8.5 s
Boom extension	20.5 s
Boom retraction	13.0 s
Crowding	5.0 s
Dumping	4.5 s

Weights

Unladen weight (24" tyres)	9770 kg
----------------------------	---------

Engine

Make / Model	Bobcat D34
Fuel	DIESEL
Rated power (ISO 14396)	74.0 kW
Rated speed	2400.0 RPM
Maximum torque at 1400 rpm	430.0 Nm
Number of cylinders	4.0
Displacement	3.41 L

Hydraulic system

Pump type	Gear pump with LS valve
Pump capacity	100.00 L/min
Relief valve pressure setting	250.00 bar
Control valve type	Open center with flow sharing & flow compensators technology

Drive system

Transmission	Hydrostatic with electronic regulation
Main Drive	Hydrostatic motor

Traction

Standard Tyres	400/80-24 / 20PR TM R4
Max speed - turtle mode (24" / 20")	8,5 / 7
Max speed - rabbit mode (24" / 20")	30 / 26

Brakes

Engine Braking	Hydrostatic
Parking and Emergency brake	Passive brake
Service Brake	Oil immersed discs

Steering

Steering Mode	2 wheel steering / 4 wheel steering / Crab-steering
---------------	-----------------------------------------------------

Fluid Capacities

Fuel tank	145.00 L
Adblue ® tank	22.40 L
Hydraulic tank	76.00 L
Hydraulic system	157.00 L

Environmental

Operator noise level (LpA) (EN 12053)	75 dB(A)
Level of acoustic power (LwA)	106 dB(A)
Whole body vibration (EN 13059)	1.00 ms ⁻²

Dimensions

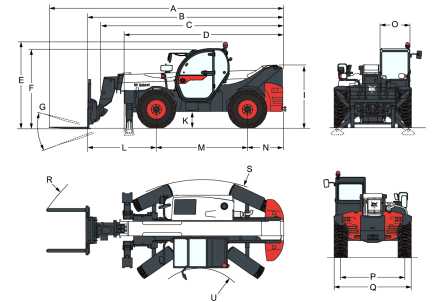

Values marked with * - 24" tyres

(A)	7313.0 mm	(L)	2151.0 mm
(B)	6108.0 mm	(M)	2850.0 mm
(C)	5709.0 mm	(N)	1107.0 mm
(D*)	4950.0 mm	(O)	930.0 mm
(E*)	2673.0 mm	(P)	1992.0 mm
(F*)	2520.0 mm	(Q)	2418.0 mm
(G)	124.0°	(R*)	5745.0 mm
(I*)	1956.0 mm	(S*)	4150.0 mm
(K*)	509.0 mm	(U*)	1519.0 mm

Load Charts

Load Charts

