

T40-180SLP 100 V R-Series Telescopic Handler

Telescopic Specifications

Performance

| | |
|---|------------|
| Rated capacity | 4000 kg |
| Capacity (at max. height on tyres) | 1000 kg |
| Capacity at max. height on stabilizers | 2500 kg |
| Capacity at max. reach on stabilizers | 500 kg |
| Lifting height | 16200.0 mm |
| Lifting height on stabilizers | 17466.0 mm |
| Tilt Breakout force | 12300 daN |
| Drawbar pull (24" tyres) | 4900 daN |
| Max. gradeability (24" tyres) | 27.0° |
| Max. reach | 13680.0 mm |
| Lifting height on stabilizers (24" tyres) | 17466.0 mm |
| Max. reach on stabilizers (24" tyres) | 13680.0 mm |

Cycle times

| | |
|-----------------|--------|
| Boom raising | 14.0 s |
| Boom lowering | 8.5 s |
| Boom extension | 31.5 s |
| Boom retraction | 20.5 s |
| Crowding | 5.0 s |
| Dumping | 4.5 s |

Weights

| | |
|----------------------------|----------|
| Unladen weight (24" tyres) | 10390 kg |
|----------------------------|----------|

Engine

| | |
|----------------------------|------------|
| Make / Model | Bobcat D34 |
| Fuel | DIESEL |
| Rated power (ISO 14396) | 74.0 kW |
| Rated speed | 2400.0 RPM |
| Maximum torque at 1400 rpm | 430.0 Nm |
| Number of cylinders | 4.0 |
| Displacement | 3.41 L |

Hydraulic system

| | |
|-------------------------------|--|
| Pump type | Gear pump with LS valve |
| Pump capacity | 100.00 L/min |
| Relief valve pressure setting | 250.00 bar |
| Control valve type | Open center with flow sharing & flow compensators technology |

Drive system

| | |
|--------------|--|
| Transmission | Hydrostatic with electronic regulation |
| Main Drive | Hydrostatic motor |

Traction

| | |
|-------------------------------------|------------------------|
| Standard Tyres | 400/80-24 / 20PR TM R4 |
| Max speed - turtle mode (24" / 20") | 8,5 kph |
| Max speed - rabbit mode (24" / 20") | 30 kph |

Brakes

| | |
|-----------------------------|--------------------|
| Engine Braking | Hydrostatic |
| Parking and Emergency brake | Passive brake |
| Service Brake | Oil immersed discs |

Steering

| | |
|---------------|---|
| Steering Mode | 2 wheel steering / 4 wheel steering / Crab-steering |
|---------------|---|

Fluid Capacities

| | |
|------------------|----------|
| Fuel tank | 145.00 L |
| Adblue ® tank | 22.40 L |
| Hydraulic tank | 76.00 L |
| Hydraulic system | 173.00 L |

Environmental

| | |
|---------------------------------------|-----------------------|
| Operator noise level (LpA) (EN 12053) | 75 dB(A) |
| Level of acoustic power (LwA) | 106 dB(A) |
| Whole body vibration (EN 13059) | 1.00 ms ⁻² |

Dimensions

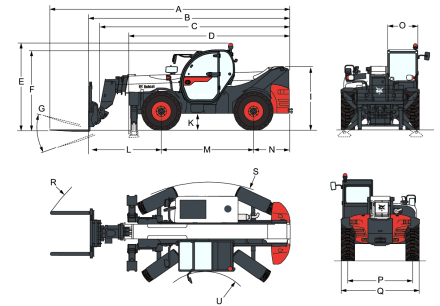

Values marked with * - 24" tyres

| | | | |
|------|-----------|------|-----------|
| (A) | 7425.0 mm | (L) | 2263.0 mm |
| (B) | 6220.0 mm | (M) | 2850.0 mm |
| (C) | 5821.0 mm | (N) | 1107.0 mm |
| (D*) | 4950.0 mm | (O) | 930.0 mm |
| (E*) | 2673.0 mm | (P) | 1992.0 mm |
| (F*) | 2520.0 mm | (Q) | 2418.0 mm |
| (G) | 124.0° | (R*) | 5840.0 mm |
| (I*) | 1956.0 mm | (S*) | 4150.0 mm |
| (K*) | 509.0 mm | (U*) | 1519.0 mm |

Load Charts

Load Charts

