

SPECIFICATION

JCB E-TECH



ELECTRIC COMPACT TELEHANDLER | 525-60E

Battery capacity: 96V 24kWh Zero Emissions. Lithium-ion Technology.

JCB

100% electric. Zero emissions.

JCB is leading the way in clean technology and reducing harmful emissions. That's why we are introducing JCB E-TECH, a new generation of electric products with zero emissions at point of use that don't compromise on performance. The new 525-60E is the first of the electric generation and JCB's first fully electric compact telehandler. It lets you do your average working shift on a single charge*, giving you access to a whole new world of possibilities.

*Dependent on ambient temperature and working duty cycle.



LOW NOISE

Low noise levels make the new 525-60E ideal for working in urban areas, indoors, out of hours and operating in sensitive environments.

SAFER WORKING

No trailing tethers, zero emissions, low noise levels and other innovative features provide peace of mind for working safely and efficiently.

ZERO EMISSIONS

The new 525-60E compact telehandler is part of JCB's 100% electric E-TECH range, with zero emissions, less noise and zero compromise on performance.



ZERO COMPROMISE

Get the same high performance as a conventional machine with powerful lithium-ion technology. 24kWh battery powers an average working shift.

*Dependent on ambient temperature and working duty cycle.



REDUCED COSTS

The new 525-60E has considerably lower operating costs with maintenance-free batteries, minimal daily checks and less servicing.

STATIC DIMENSIONS

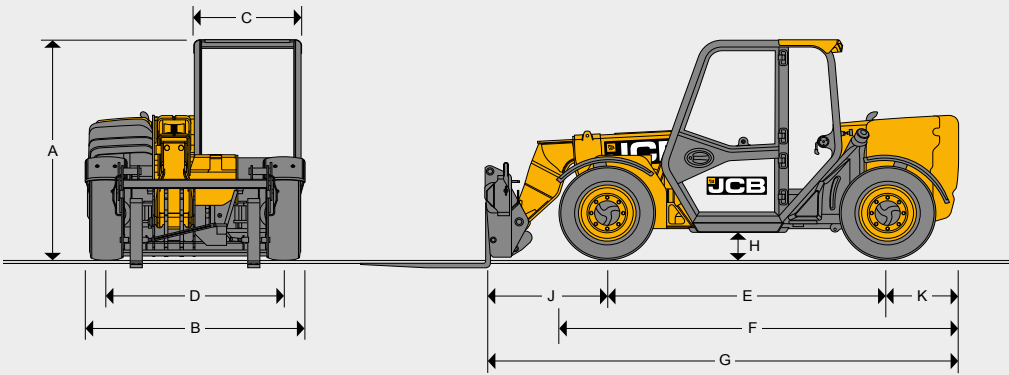

A	Overall height*	m	1.89
B	Overall width (over tyres)*	m	1.84
C	Inside width of cab	m	0.88
D	Front track	m	1.53
E	Wheelbase	m	2.39
F	Overall Length to front tyres	m	3.38
G	Overall length to front carriage	m	4
H	Ground clearance	m	0.22
J	Front wheel centre to carriage	m	1.02
K	Rear wheel centre to rear face	m	0.6
	Outside turn radius (over tyres)	m	3.7
	Carriage roll back angle	degrees	11
	Carriage dump angle	degrees	114
	Weight	kg	5145
	Tyres	industrial	12x16.5

*Dependant upon tyre specified.

LIFT PERFORMANCE

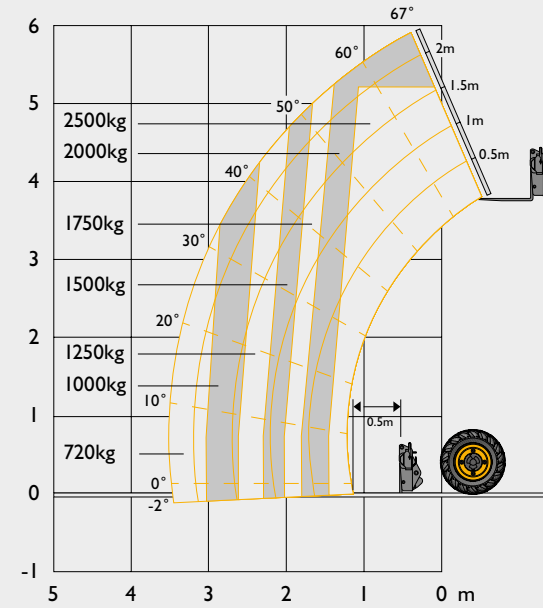

Maximum lift capacity	kg	2500
Lift capacity to full height	kg	2000
Lift capacity at full reach	kg	720
Lift height	m	6
Reach at maximum lift height	m	-0.15
Maximum forward reach (to front of carriage)	m	3.5

Complies with stability test EN1459-1

POWER SOURCE

Battery type	Lithium-ion
Gross capacity	24kWh
System voltage	96V
Manufacturer	Jungheinrich

CHARGING

On-board charger allowing direct connection to AC mains power supply.		
On-board charging 3kW (240V / 16A)	25 - 80%: 5hrs 0 - 100%: 8hrs	
Rapid charging 18kW (415V / 32A)	25 - 80%: 60mins 0 - 100%: 110mins	
Charging cable plug type	16A 230V (Blue)	

MOTORS

	Traction	Hydraulic
Motor type	3 phase AC (induction)	3 phase AC (induction)
Motor power	17kW (S2)	22kW (S3)
Max speed	6000rpm	3000rpm
Peak torque	220Nm	130Nm
Manufacturer	Jungheinrich	Jungheinrich

HYDRAULICS

Internal gear pump, fitted with suction strainer and filter.		
JCB Smart Hydraulics on boom lower and retract, with separate filtration on pilot services.		
Operating system pressure	bar	245
Max flow at system pressure	ltr/min	65
Hydraulic cycle times		Seconds
Boom raise		9.4
Boom lower		6.7
Boom extend		9.6
Retract		6.0
Bucket dump		3.1
Bucket crowd		4.0

TRANSMISSION

Permanent 4WD transmission with independent drive motor and regenerative braking. Travel Speed 15kph.			
Speed	kph	Forward 15	Reverse 15

ELECTRICS

System voltage	Volt	12V & 96V
Full road lighting. Reversing light. Direction indicators. Hazard warning. Reverse alarm. Optional rise over ambient white noise reverse alarm.		

NOISE AND VIBRATION

		Measurement conditions	
A-weighted sound pressure level at operator's position (LpA)	dB(A)	71	Determined in accordance with the test method defined in ISO 6396 and the dynamic test conditions defined on 2000/14/EC.
A-weighted sound power level emitted by the machine (LwA)	dB(A)	93.6	Guaranteed equivalent sound power (external noise) determined in accordance with the dynamic test conditions defined in 2000/14/EC.
Whole body vibration (m/s ²)	(m/s ²)	1.24	ISO 2631-1:1997 normalised to an 8h reference period and based upon a test cycle defined in SAE J1166.
Hand-arm vibration (m/s ²)	(m/s ²)	1.27	ISO 5349-2:2001 dynamic test conditions.

SERVICE FILL CAPACITIES

Hydraulic system	litres	45
------------------	--------	----

AXLES

Front and rear drive JCB axles: epicyclic hub reduction drive/steer axles.

BRAKES

Service brakes: Hydraulically operated self-adjusting.

Parking brake: SAHR Handbrake self adjusting operated by in-cab switch.

BOOM AND CARRIAGE

Boom is manufactured from high tensile steel. Low maintenance, hard wearing pads.

Carriage Options: JCB Q-Fit, JCB compact toolcarrier, Skid-Steer, Euro Hitch, Manitou and Pin & Cone.

STEERING

Hydrostatic power steering with power track rods on both axles.

Three steer mode options: Front wheel steer, all wheel steer, crab steer, operated from in the cab by a selection lever.

CAB

Quiet, safe and comfortable cab conforms to ROPS ISO 3471 and FOPS ISO 3449. Tinted glass all round, heated front, rear and right-hand side, laminated roof screen. Roof bars, front screen and roof screen wipers and heater/screen demister. Rear opening window with wash/wipe. Battery charge, hourmeter, road speed indicator, clock and inclinometer. Adjustable, heated air suspension seat, tilt steer column, SAHR brake switch, floor mounted throttle and brake pedals.

Hydraulic controls: Single lever servo joystick, incorporating forward/neutral/reverse, with progressive extend/retract and auxiliary.

Load Moment Indicator: Automatic eye level audio-visual load moment indicator warning system receiving a signal from a load sensor on the rear axle. This system continuously monitors the machine's forward stability and leaves the operator in control at all times.

OPTIONS

Options: Front, rear and boom working lights, green/amber flashing beacon, fire extinguisher, front screen guard, boom end auxiliary services, sunblind, radio kit, carriage hydraulic locking, 2-speed and intermittent front wash/wiper. 1.2kW on-board charger (110V / 16A compatible).

Attachments: Contact your local dealer for details of the comprehensive range.

*Adaptive Load Control for EU territories conforms to EN15000.









100% electric. Zero emissions.

Your nearest JCB dealer

Electric Compact Telehandler 525-60E

Battery capacity: 96V 24kWh Zero Emissions. Lithium-ion Technology.

JCB Sales Limited, Rokecster, Staffordshire, United Kingdom ST14 5JP.

Tel: +44 (0)1889 590312 Email: salesinfo@jcb.com

Download the very latest information on this product range at: www.jcb.com

©2022 JCB Sales. All rights reserved. No part of this publication may be reproduced, stored in a retrieval system, or transmitted in any form or by any other means, electronic, mechanical, photocopying or otherwise, without prior permission from JCB Sales. All references in this publication to operating weights, sizes, capacities and other performance measurements are provided for guidance only and may vary dependant upon the exact specification of machine. They should not therefore be relied upon in relation to suitability for a particular application. Guidance and advice should always be sought from your JCB Dealer. JCB reserves the right to change specifications without notice. Illustrations and specifications shown may include optional equipment and accessories. All images are correct at time of print. The JCB logo is a registered trademark of J C Bamford Excavators Ltd.

32110 en-GB 07/24 Issue 3

