

Mecalac

MDX
SERIES



MDX
SERIES **Mecalac**





MDX SERIES

THE COMBINATION OF SAFETY AND DESIGN

For Mecalac, there is no such thing as small machines or small challenges. In the development of its dumpers, the safety of the users was non negotiable – whatever the cost. With its know-how in terms of practical innovation and common sense strategy, the R&D department has transformed the 6- and 9-tonne dumpers of the existing range by incorporating the added value that is Mecalac's strength, which is taking a fresh look at a machine, and now the keystone of urban projects.

How? By imagining a cab that "changes everything", with no equivalent on the market and that fits perfectly into the existing design of its dumpers.



6.9.MDX

DESIGN - LOGISTICS OF THE JOBSITE

AN EFFICIENT SOLUTION TO MATERIAL MOVEMENT ON YOUR JOB SITE

“Site dumpers are a simple concept that can quickly change the dynamic of a jobsite. Compact and manoeuvrable machines capable of carrying payloads of up to 10tons they provide an efficient solution to material movement on the jobsite.

The dumpers ability to work in confined spaces and in a wide range of ground conditions sets them apart from road going trucks typically used for material movement. The large carrying capacity significantly reduces the number of cycles required to move material when compared to either a wheeled loader or skid steer, increasing efficiency, reducing site traffic and ground disturbance.

These attributes create a machine that is a cost effective and efficient off highway material movement solution.”

Adam Phillips
Product Marketing MCE UK





WATCH THE VIDEO



MDX 6.9

SAFETY CONSCIOUS

**EXCELLENT ACCESS
TO THE CABIN AND
ISO5006 COMPLIANT
VISIBILITY**



Large self cleaning steps provide stair like access to the comfortable cabin. Large glazed areas and forward facing camera ensure compliance to relevant standards.







SAFETY CONSCIOUS

EXCELLENT ACCESS

ENTERING AND EXITING THE MACHINE IS ALWAYS SAFE DUE TO THE STAIR-LIKE ACCESS

*Thanks to the large stair like steps and full length
grab rails the operator is able access the cabin
without excess effort or taking any risks.*

The completely redesigned access system for the MDX site dumpers features large self clearing foot steps organised like a stairway, the solid back plate significantly reduces the risk of material build up on the steps, increasing safety. With a full length hand rail located on the A-pillar and a door mounted hand rail, 3 points of contact can be easily maintained when accessing the cabin.



WATCH THE VIDEO



WATCH THE VIDEO





SAFETY CONSCIOUS

OPERATORS ENVIRONMENT

WHETHER THE FULLY GLAZED CABIN OR ROPS/FOPS CANOPY WITH WINDSCREEN, OPERATOR COMFORT AND ERGONOMICS IS ALWAYS CONSIDERED

The unique design of the Mecalac MDX range of dumpers is that the Cabin or FOPS canopy are mounted on isolating mounts designed to reduce the vibration and noise transmitted to the operator. Well positioned operators controls ensure a comfortable working environment for the operator.







WATCH THE VIDEO



SAFETY CONSCIOUS

VISIBILITY ISO5006 COMPLIANT

**EXCELLENT ALL AROUND NATURAL
VISIBILITY AND A FORWARD FACING
CAMERA ENSURES A SAFE MACHINE
ON SITE THAT IS FULLY COMPLIANT**

The cabin or FOPS canopy feature wide A pillar positioning and a curved front windscreen to ensure that natural visibility is maximised, combined with the fully integrated dash board there are no extra screens or brackets that could hamper visibility. The addition of the forward facing camera ensures compliance to ISO5006.





MDX 6.9

OPTIMAL PERFORMANCE

MDX machines are equipped with numerous technical characteristics for optimal efficiency on all types of terrain.

- Off-road mobility
- Robustness built in!
- Versatility



6MDX

MECALAC

MECALAC

6.9 MDX



PERFORMANCE

OFF-ROAD MOBILITY

AN ARTICULATED AND OSCILLATING CHASSIS ENSURES THE MDX RANGE OF DUMPERS HAVE EXCELLENT MANOEUVRABILITY AND OFF-ROAD CAPABILITY

All mecalac site dumpers are designed with high ground clearance to enable operation on the roughest terrain, Permanent 4 wheel drive and large oscillation angles ensure the wheels keep in contact with the ground and maintain traction in all conditions.

Large turning angles ensure the machines remain manoeuvrable so that access to difficult locations remains possible with the 9MDX being the most manoeuvrable dumper in its class!





Mecalac

Mecalac



PERFORMANCE

ROBUSTNESS BUILT IN!

**65 YEARS OF DUMPER
PRODUCTION HAS LEAD
TO MACHINES DESIGNED
SPECIFICALLY TO MEET THE
TOUGH DEMANDS OF NEW
CONSTRUCTION SITES**

'Rental tough' site dumper design has ensured that Mecalac site dumpers have remained a long lasting and reliable part of your business. The use of solid rear panels ensures the highest level of protection to the cooling pack and engine, the latest design also see the addition of LED lights that are recessed into the casting for excellent protection.





PERFORMANCE

VERSATILITY

**WHETHER CARRYING OUT
BULK MATERIAL MOVEMENT
OR WORKING IN CONFINED
SPACES WE HAVE A SKIP
DESIGN SUITABLE**

Choose between the straight tip skip and the swivel tip skip to match the needs of your job site. Straight tip skips offer large volumetric capacity, perfect for bulk material movement. Swing tip skip allows the machine to deposit loads anywhere within a 180 degree arc, this allows machines to unload into trenches whilst working in a single lane of traffic.







MDX 6.9

OPERATOR INTERACTION

Ease of operator interaction has been considered with the MDX. All controls are ready to hand, large glazed areas provide great visibility and servicing has never been easier.

- User friendliness
- Ease of maintenance
- Shield technology inside
- Hazard detection
- Capture telematics







WATCH THE VIDEO



OPERATOR INTERACTION

USER FRIENDLINESS

WHETHER THE FULLY GLAZED CABIN OR ROPS/FOPS CANOPY WITH WINDSCREEN, OPERATOR COMFORT AND ERGONOMICS IS ALWAYS CONSIDERED

A combination of simple operator controls and an uncluttered cabin ensure the operator can carry out their tasks with ease. Operator comfort is guaranteed due to the high back operators seat and ergonomic positioning of all the machine controls.

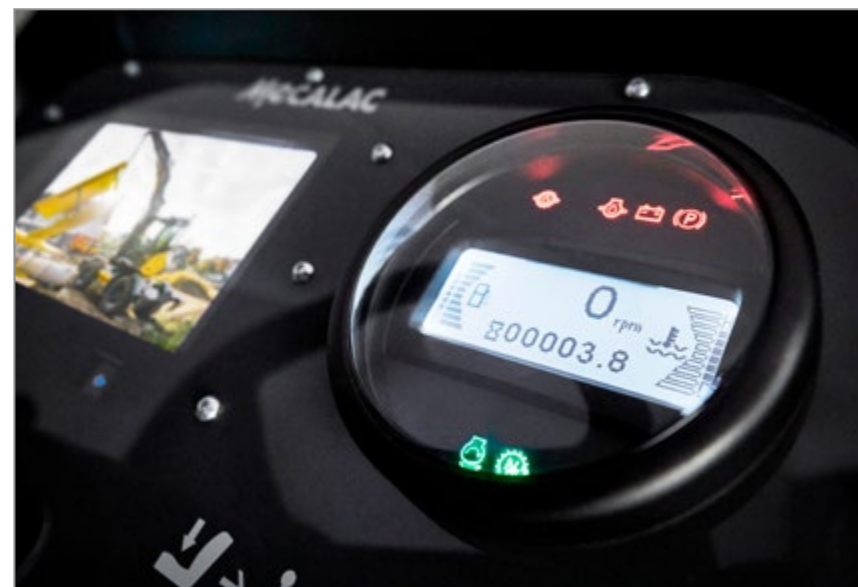



WATCH THE VIDEO





OPERATOR INTERACTION

EASE OF MAINTENANCE

EXCELLENT ENGINE ACCESS FOR SERVICING AND DAILY CHECKS. GULL WING TYPE DOORS

The full length gull wing doors provide easy access into the engine bay where all daily checks can be carried out with your 'feet on the ground'. A service panel integrated into the rear of machine enables access directly into the cooling pack or ease of cleaning.





OPERATOR INTERACTION

SHIELD TECHNOLOGY INSIDE

INNOVATION LEAD BY SAFETY. SHIELD OFFERS INDUSTRY FIRST FEATURES FOR SITE DUMPER SAFETY

To ensure the safest site dumper on the Market Mecalac has developed an array of safety technology to ensure not only the safety of the operator but also those people working around the machine. SHIELD will be fitted as standard on all MDX site dumpers with the option to upgrade to SHIELD Pro.

Standard SHIELD includes features such as a start & drive interlock to ensure the operator is wearing their seatbelt before operating the machine. Stop-start and Idle shut off ensure the machine is not left running for longer than required, saving fuel and reducing operating hours, therefore extending service intervals and maintaining residual value.

SHIELD PRO includes features such as skip operation interlocks, safe working angle monitoring and adjustable speed limiting to further enhance the safety of the machine.

BEFORE WORK *Sit, Belt, Start, Drive*

Before driving the site dumper the operator must sit on the seat and then fasten his seatbelt before the machine will start or drive.



DURING WORK *A number of innovative solutions*

Shield technology offers a number of unique solutions to aid safety during the working day.



CUSTOM SPEED LIMITER *Safe Site Management*

Using the downloadable application it is possible to adjust via bluetooth the maximum speed that the machine can travel.





SAFE WORKING ANGLE MONITORING

Safe system for working on slopes

The machine is constantly monitoring the angle at which it is operating, a warning is given when approaching the maximum safe working angle. When the maximum angle is reached the engine rpm is limited to stop the machine progressing into a further unstable situation.

SKIP INTERLOCKS

Improving visibility and stability

When the machine speed is above 5km/h the operation of the skip is removed. When the machine speed drops below 5km/h the skip operation is enabled, however the maximum speed is then limited.

SHIELD SAFETY PACKS

Improving site dumper safety

As standard all MDX site dumpers are fitted with the SHIELD technology package to ensure a great level of safety as standard. Additional technology can be added by upgrading to SHIELD Pro, the addition of many slope dependant features and by using the App machine maximum speed and idle shutoff time can be adjusted to suit the requirements of individual sites.

FEATURE	SHIELD	SHIELD PRO
Start & Drive interlock	•	•
Seatbelt warning	•	•
TUV speed limiter (25kph)	•	•
Park brake neutral warning	•	•
Idle shut off (15minutes)	•	
Stop - Start system	•	•

FEATURE	SHIELD	SHIELD PRO
Auto park brake test	•	•
Service warning	•	•
Skip interlock		•
Skip up speed limiter		•
SHIELD Pro App (for Tablets)		•
Adjustable speed limiter		•

FEATURE	SHIELD	SHIELD PRO
Adjustable idle shut-off		•
Tilt warning & limiter		•
Roll-over lockout		•
Fuel loss warning	•	•
Capture telematics ready	•	•
Hazard detection ready		•



OPERATOR INTERACTION

HAZARD DETECTION

A ROBUST SOLUTION TO PROVIDE ADDITIONAL AID TO OPERATORS OF FORWARD FACING SITE DUMPERS

The system is designed to detect objects in front of the working machine which may have been overlooked by the operator. A forward facing sensor combined with an audio visual alarm alert the operator when an object is within range and sequential LED lights illuminate to show which zone the object has entered. Dedicated software aims to reduce the number of unwanted warnings, such as when the machine is stationary or moving away from an object.



ROBUSTNESS

Built to be Rental Tough

The forward facing radar head is built from stainless steel and features a 6mm polycarbonate front to ensure high levels of impact protection.



OPERATOR AWARENESS

Audible and Visual

Visual warnings are displayed on the machine display screen that is integrated into the dash board directly in front of the operator. The audible warning alarm is also integrated into dash board.





OPERATOR INTERACTION

CAPTURE TELEMATICS

**GLOBAL SOLUTION FOR
MACHINE AND FLEET
MANAGEMENT, TELEMATICS
CAN SAVE YOU TIME AND
MONEY.**

Simple, Accessible, Informative. Capture makes equipment monitoring easy. Capture is capable of providing information such as machine location, distance travelled and daily hours completed. Alongside this, integration with the ECU allows users to access real time fuel consumption data, service planning functionality and geo fencing reports.





GEO-FENCING

Where and when

The ability to create a work area map within the telematics software that can send alerts when the machine leaves that area.



WATCH THE VIDEO

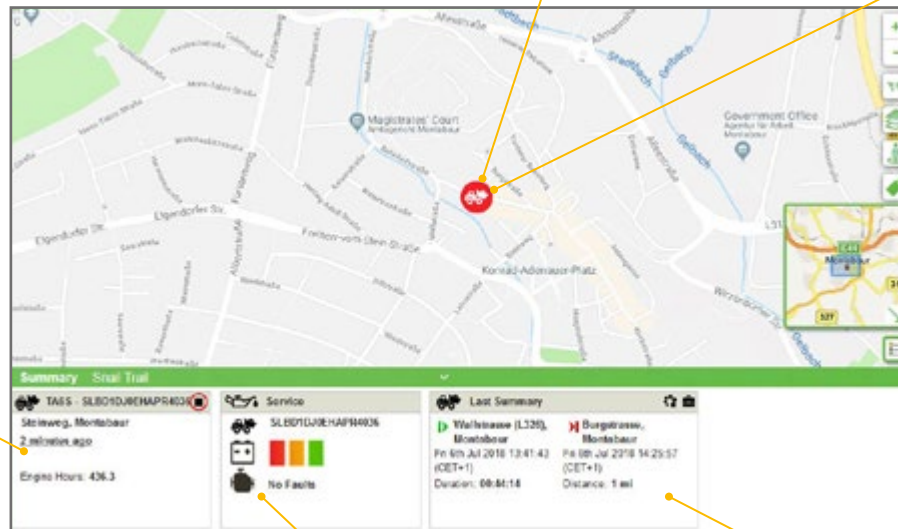

MACHINE INFO

Location & run info

A brief summary of the machine location, time since last operation and then the engine hours.



MACHINE MOVEMENTS

Routes of the worksite

Capture provides the ability to view the exact routes taken when working. This will also show exactly where and when any potential machine faults had occurred.

SERVICE INFORMATION

Keep track of maintenance

Capture provides the exact serial number of the machine, battery status and then a display of any existing fault codes.

MOVEMENT SUMMARY

Last Journey Report

A summary of the last journey made by the machine, including the exact time, date, duration and distance.



MDX 6.9

SET UP YOUR MDX

The new MDX comes standard equipped with a number of features, while at the same time remaining attentive to the specifications required by various types of customers: landscape and earthwork contractors, public works' professionals, municipal authorities, etc. Whether a straight or swing skip, full cabin or canopy, heating or AC there is a combination that will suit all requirements.

MDX

**OPERATORS
ENVIRONMENT**



SKIP TYPE



TRANSMISSION



**STANDARD
FEATURES**



**AVAILABLE
OPTIONS**



TECHNICAL DATA

ENGINE	6MDX	9MDX
Turbo charged engine with intercooler, EGR valve and Diesel Particulate Filter (DPF, Passive Regeneration), complying with regulation	Tier 4 Final Stage IIIB	Tier 4 Final Stage IIIB
Diesel 4 in-line cylinders	PERKINS 854	PERKINS 854
Horsepower (DIN 70020)	55 kW (74hp)	55 kW (74hp)
Engine speed	2,300 rpm	2,300 rpm
Maximum torque	424 Nm at 1200 rpm (313 ft.lbf at 1200 rpm)	424 Nm at 1200 rpm (313 ft.lbf at 1200 rpm)
Cubic capacity	3400 cm ³ (207 in ³)	3400 cm ³ (207 in ³)
Cooling	water	water
Air filter, cyclonic, dry, cartridge	•	•
Fuel tank capacity	65 L	

TRANSMISSION	6MDX	9MDX
Type	Powershuttle via transfer box to front & rear axles	
Drive	4 / 4 Forward and Reverse - Permanent 4WD	
Electronically controlled travel direction control on steering column	•	•
Tyre Size	405-70-20 14PR	500-60-22.5 16PR
Maximum Speed	26 km/h (16 mph)	25 km/h (15 mph)
Gradeability (Defined by maximum safe working angle)	25%	20%

SKIP CAPACITY	6MDX		9MDX	
Payload	6000 kg (13,228 lb)		9000 kg (19,842 lb)	
Volume:	Straight	Swing	Straight	Swing
- Water	1830 l	1580 l	2014 l	1902 l
- Struck	2680 l	2399 l	3775 l	3318 l
- Heaped	3740 l	3085 l	4573 l	4096 l

MACHINE WEIGHT	6MDX	9MDX
In running order, with 75 kg (165 lb) operator, fuel tank full		
- Straight Skip, Glazed Cabin	4775 kg (10,527 lb)*	5495 kg (12,114 lb)*
- Swing Skip, Glazed Cabin	4995 kg (11,012 lb)*	5835 kg (12,863 lb)*

* Specifications are subject to change

HYDRAULIC SYSTEM	6MDX	9MDX
Pump Type		Gear
Flow Rate		65 l/min
Operating Pressure	172 bar (2495 psi)	210 bar (3045 psi)
Steering System	Orbitrol hydrostatic steering unit powering a central hydraulic steering cylinder	

BRAKE SYSTEM	6MDX	9MDX
Working Brake	Hydraulic boosted foot Brake - Oil immersed discs on front/rear	
Parking Brake	Over centre parking brake - Dry disc on gearbox	

ENVIRONMENTAL	6MDX	9MDX
Sound power level (LWA _d)		101 dB
Noise Compliance	Noise - Equipment used outdoors directive 2000/14/EC	
Hand Arm Vibration (Defined by EN474-1 for all operations)	<2.5 m/s ²	
Whole body vibration (Defined by ISO/TR25398 for a work cycle)	0.529 (0.264 m/s ² uncertainty)	

NOTE
 - METRIC MEASUREMENTS ARE THE CRITICAL VALUES
 • 1 Litre = 0.26417 US Liquid Gallons
 • 1 Litre = 0.21997 Imperial Liquid Gallons

TECHNICAL DATA

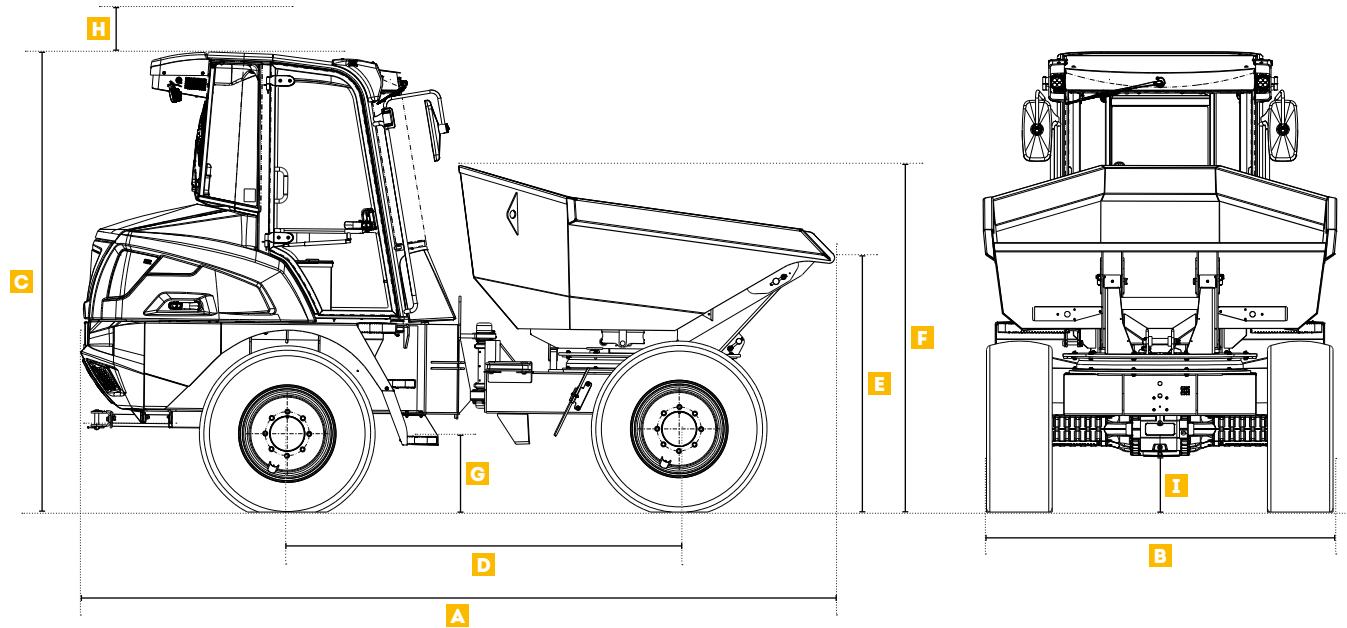

MACHINE DIMENSIONS	6MDX		9MDX	
	STRAIGHT mm (ft in)	SWING mm (ft in)	STRAIGHT mm (ft in)	SWING mm (ft in)
A Overall length	4452 (14'7")	4710 (15'5")	4585 (15'1")	4734 (15'6")
B Overall width	2300 (7'7")	2211 (7'3")	2502 (8'3")	2364 (7'9")
C Overall height	2875 (9'5")	2875 (9'5")	3384 (11'1")	3384 (11'1")
D Wheelbase	2450 (8')	2450 (8')	2450 (8')	2450 (8')
E Height to skip lip	1546 (5'1")	1690 (5'7")	1682 (5'6")	1827 (5'11")
F Height to back of skip	1998 (6'7")	2167 (7'1")	2292 (7'6")	2483 (8'2")
G Height to first step	472 (1'7")	472 (1'7")	509 (1'8")	509 (1'8")
H Additional height for beacon	140 (5.5")	140 (5.5")	140 (5.5")	140 (5.5")
I Ground Clearance	347 (1'2")	347 (1'2")	396 (1'4")	396 (1'4")

MECALAC FRANCE S.A.S.
2, avenue du Pré de Challes
Parc des Glaisins – CS 40230
Annecy-le-Vieux
FR - 74942 Annecy Cedex
Tel. +33 (0)4 50 64 01 63

**MECALAC BAUMASCHINEN
GMBH**
Am Friedrichsbrunnen
D-24782 Büdelsdorf
Tel. +49 (0)43 31/3 51-319

**MECALAC CONSTRUCTION
EQUIPMENT UK LTD**
Central Boulevard,
ProLogis Park
Coventry, CV6 4BX, UK
Tél. +44 (0)24 7633 9539

**MECALAC İŞ MAKİNELERİ
SAN VE TIC. LTD. ŞTİ.**
Ege Serbest Bölgesi Nilüfer 1 Sok. No: 34
35410, Gaziemir
İzmir - Türkiye
Tel. +90 232 220 11 15



WWW.MECALAC.COM