



SOLID
TO SUCCEED

ARTICULATED BOOM LIFT

XGA18ACK



The print does not belong to the contract, nor a part of the vehicle purchase contract. We reserve the right to revise the product model, parameters, configuration based on the continuous improvement requirements of the product, without prior notice. Pictures are for reference only, and the specific product shall depend on the real product.

XGA18ACK

Articulated boom lift

FEATURES

MEASUREMENTS

18m working height
up to 256/350kg lift capacity

PRODUCTIVITY

1.83m x 0.76m working platform
256/350kg platform load capacity
160° platform rotation
4-wheel drive
2 steering wheels
30% theoretical gradeability
Horn
Solid rubber tires
Platform automatic leveling system
Fully proportional multi-function controls
Enable switch
Hourmeter record
Tilt alarm
Lift and lower alarm
Drive alarm
Lockable canopy
High/Slow speed mode
Flashing beacon

POWER

400Ah/48V Lead-acid batteries
1.9kW/12V DC emergency control unit
12V DC proportional control

OPTIONS

Axle balancing system
Turntable 360° continuous rotation
Platform working light
Tool tray
Non-marking tires
412Ah/51.2V Lithium batteries

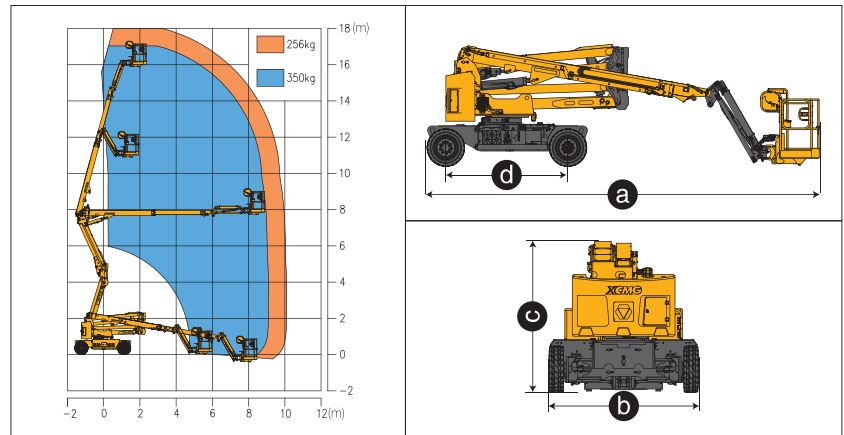

Item	Unit	XGA18ACK
Working height	m	18
Platform height	m	16
Working radius	m	10.1
Lift capacity	kg	256/350
Occupant capacity	-	2
1st Boom luffing range	°	0~65
2nd Boom luffing range	°	-11~+75
Fly jib luffing range	°	-65~+70
Turntable rotation	°	355
Platform rotation	°	160
Drive Speed (retracted/extended)	km/h	4.8/0.6
Turning Radius (inside/outside)	m	3.2/4.7
Tailswing	mm	0
Ground clearance	mm	250
Gradeability	%	30
Tires	-	250-15/7.5
Control system	-	12V DC proportional control
Emergency control unit	kW/V	1.9/12 DC
Batteries	V/Ah	48/400 Lead-acid (standard) 51.2/412 Lithium (optional)
Charger	V/A	48/35 Lead-acid (standard) 48/60 Lithium (optional)
Main power unit	kW/V	12/32
Drive Motor	kW/V	3.3/32
Hydraulic tank	L	82
Weight	kg	8600
Platform size	mm	1830x760
a Length (transportation)	mm	7575/7550
b Width	mm	2320
c Height	mm	2350
d Wheelbase	mm	2360

SOLID TO SUCCEED