



SOLID
TO SUCCEED

TELESCOPIC BOOM LIFT

XGS20ACK



The print does not belong to the contract, nor a part of the vehicle purchase contract. We reserve the right to revise the product model, parameters, configuration based on the continuous improvement requirements of the product, without prior notice. Pictures are for reference only, and the specific product shall depend on the real product.

XGS20ACK

Telescopic boom lift

FEATURES

MEASUREMENTS

20.5m working height
Up to 300kg lift capacity

PRODUCTIVITY

4 driving wheels
2 Steering wheels
Axle balance system
Lift and lower alarm
Horn
Overload alarm
45% theoretical gradeability
360° continuous turntable rotation
160° platform rotation
Emergency power unit
4 wheel brake system
Automatic leveling of platform
Proportional handle control
Enable switch
Hourmeter recorder
Drive alarm
Initiative anti-extrusion system
Solid rubber tires

POWER

400Ah/48V Lead-acid battery
12V DC auxiliary power

OPTIONS

Tool tray
Work light assembly
non-marking tires
412Ah/51.2V Lithium battery

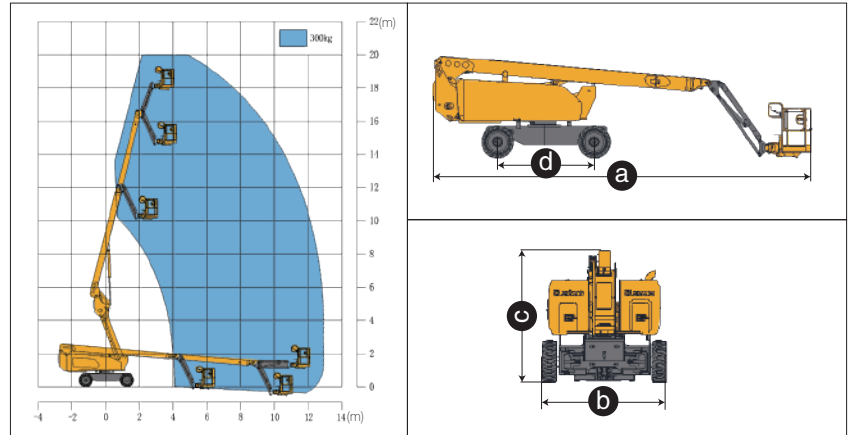

Item	Unit	XGS20ACK
Working height	m	20.5
Platform height	m	18.5
Working radius	m	13.2
Lift capacity	kg	300
Occupant capacity	-	3
Boom luffing range	°	-5~+76
Fly jib luffing range	°	-65~+70
Turntable rotation	°	360
Platform rotation	°	160
Drive speed (retracted/extended)	km/h	4.8/0.6
Turning radius (inside/outside)	m	3.1/5
Tailswing	mm	1630
Ground clearance	mm	300
Gradeability	%	45
Tires	-	835×295
Battery	V/Ah	48/400 Lead-acid (standard) 51.2/412 Lithium (optional)
Charger	V/A	48/35 Lead-acid (standard) 48/60 Lithium (optional)
Hydraulic tank	L	103
Weight	kg	8600
Platform size	mm	1830×760
a Length (transportation)	mm	9800/7400
b Width	mm	2490
c Height	mm	2640
d Wheelbase	mm	2500

SOLID TO SUCCEED