

CP300

CP series



TECHNICAL SPECIFICATIONS

Working weight	380 Kg
Excavator weight	2/10 ton
Cylinder force	22 t
Cylinders working pressure	250 bar
Cylinder oil flow	30/50 l/min
Rotation engine pressure	80 bar
Rotation oil flow (Min/Max)	2/3 l/min
Max jaws opening (A) PR	430 mm
Max jaws opening (A) SC	220 mm
Max jaws opening (A) FR	--
FR Kit (to be mounted on PR jaws)	420 mm
Total height (B)	1100 mm
Rotation 360°	hydraulic or mechanical

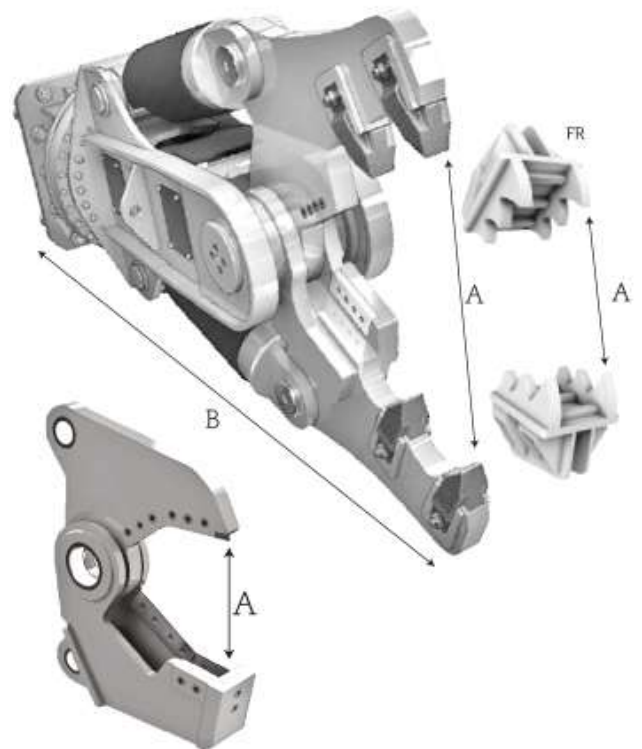

Cutting Data profile SC Jaws



80mm



60mm



30mm