

CR1500

CR series

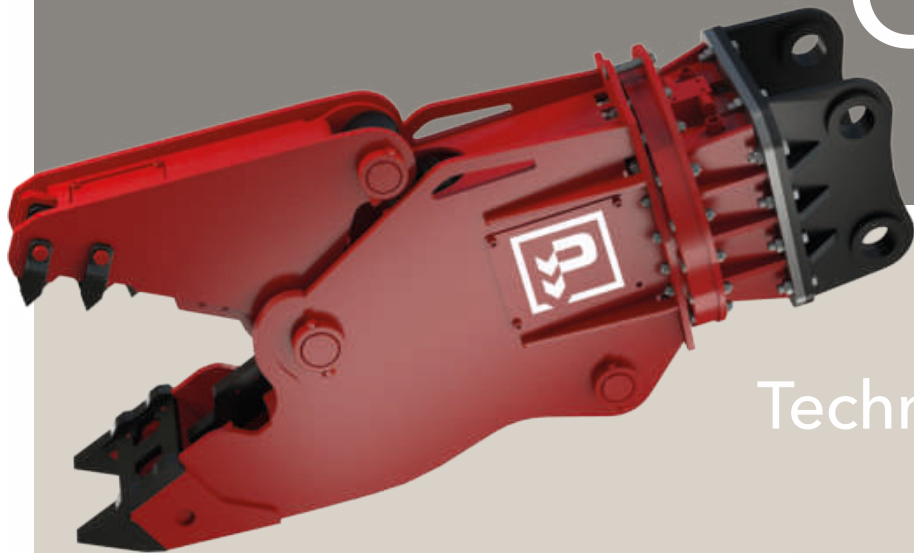

Technical Specification

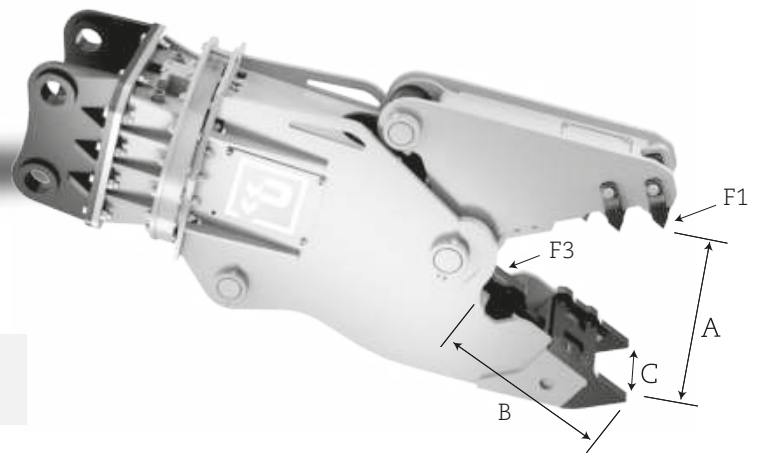

Crusher weight 1200 Kg

Excavator weight 13-16 ton

Max Jaws opening (A) 625 mm

Jaws useful length (B) 683 mm

Jaws width (upper/lower) (C) 290-460 mm

Closing force at tip (F1) 43 ton

Closing force at blades (F3) 126 ton

Opening/closing oil flow 110-160 l/min

Opening/closing pressure 350 bar

Rotation oil flow 10-12 l/min

Rotation pressure 100 bar

Rotation 360° hydraulic